

THIS DRAWING IS UNPUBLISHED. RELEASED FOR PUBLICATION  
 © COPYRIGHT BY TYCO ELECTRONICS CORPORATION. ALL RIGHTS RESERVED.

LOC	DIST	REVISIONS					
		P	LTR	DESCRIPTION	DATE	DWN	APVD
G	14		S1	REV PER ECR 07-024668	16OCT07	JR	TM

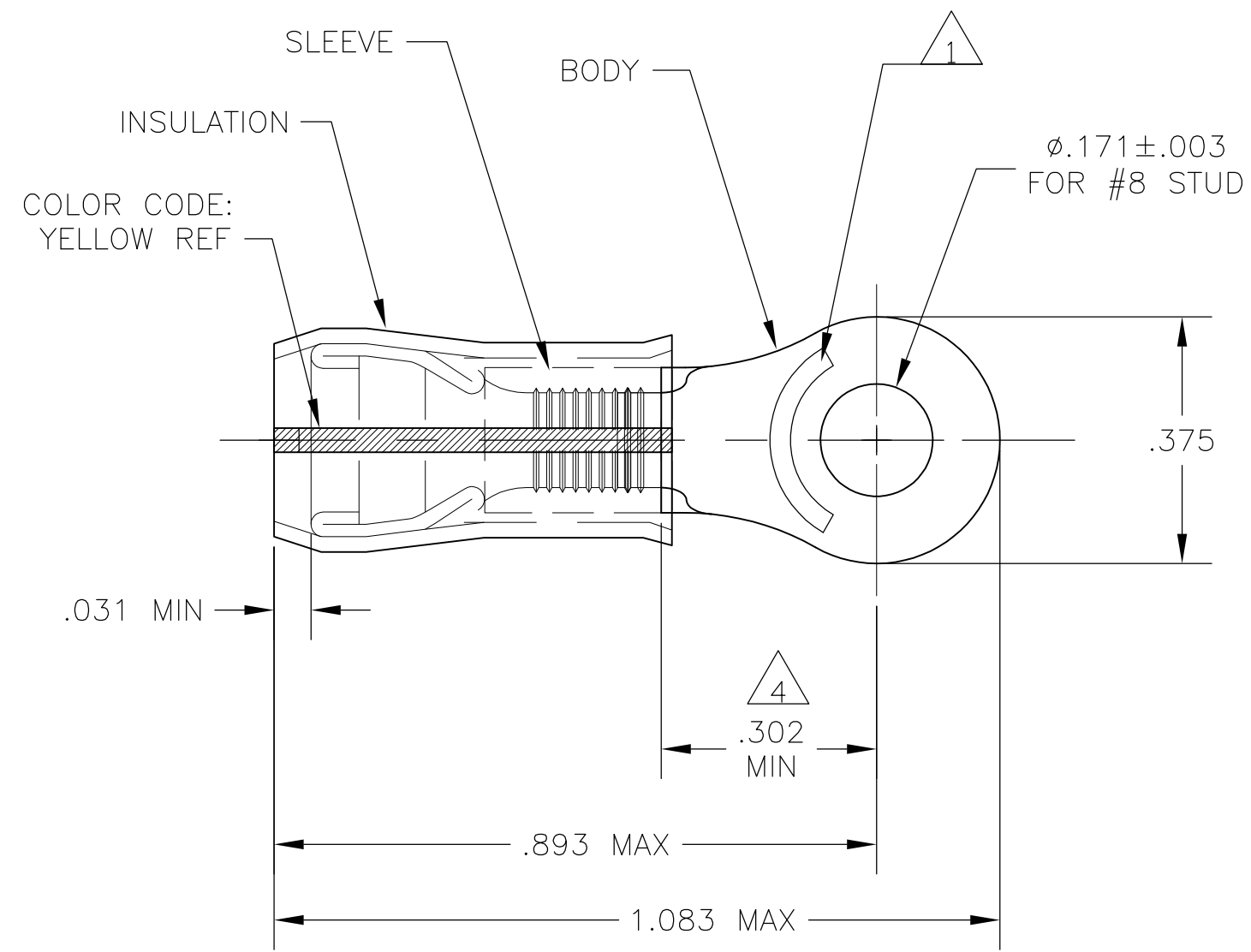

- 1 STAMP AMP 12-10\* APPROX AS SHOWN
- 2 WIRE INSULATION DIA: "A" ( SEE TABLE )
- 3 TONGUE MATERIAL THK: .039±.002
- 4 APPLIES FROM EDGE OF METAL WIRE BARREL TO CENTER OF STUD HOLE.

QTY	PACKAGE TYPE	"A"	MATERIAL & FINISH	PART NO
50	LOOSE PIECE, BOX	.150-.230	MAKE FROM 52424-1	8-53424-2
500	LOOSE PIECE	.150-.230	BODY: COPPER PER ASTM B152 GOLD PLATE PER ASTM B488, TYPE 2, GRADE C, .00005 MIN THK OVER NICKEL PLATE (QQ-N-290) .00003 MIN THK. SLEEVE: COPPER PER ASTM B152 TIN-LEAD (93-7) PLATE PER ASTM B545, ( 3% MIN LEAD CONTENT ) INSULATION: PVF2 COLOR - NATURAL	53424-3
2500	REEL, ON TAPE	.150-.230	MAKE FROM 52424-1	53424-2
500	LOOSE PIECE	.150-.260	BODY & SLEEVE: COPPER PER ASTM B152 TIN-LEAD (93-7) PLATE PER ASTM B545, ( 3% MIN LEAD CONTENT ) INSULATION: PVF2 COLOR - NATURAL	53424-6
		.150-.230		53424-1

**AMP INCORPORATED**  
**CUSTOMER SERVICE SYSTEMS**

FOR ADDITIONAL PRODUCT INFORMATION OR COPIES OF DRAWINGS AND TECHNICAL DOCUMENTS: PRODUCT INFORMATION CENTER 1-800-522-6752

FOR APPLICATION TOOLING ASSISTANCE CENTER: TOOLING INFORMATION 1-800-722-1111

FOR ORDER ENTRY: 1-800-526-5142

MAX RECOMMENDED OPERATING TEMPERATURE: 150°C MAX

VOLTAGE RATING: -

CIRCULAR MIL AREA: 2.62-6.64mm² [5,180-13,100] STRANDED

THIS DRAWING IS A CONTROLLED DOCUMENT FOR AMP INCORPORATED. IT IS SUBJECT TO CHANGE AND THE CONTROLLING ENGINEERING ORGANIZATION SHOULD BE CONTACTED FOR THE LATEST REVISION.

THIS DRAWING IS A CONTROLLED DOCUMENT.

DIMENSIONS: INCHES

TOLERANCES UNLESS OTHERWISE SPECIFIED:

0 PLC	± -
1 PLC	± -
2 PLC	± -
3 PLC	± .008
4 PLC	± -
ANGLES	± -

MATERIAL: SEE TABLE

FINISH: SEE TABLE

DWN: JR RUTH 16OCT07

CHK: T MICHIELUTTI 16OCT07

APVD: T MICHIELUTTI 16OCT07

PRODUCT SPEC: -

APPLICATION SPEC: -

WEIGHT: -

CUSTOMER DRAWING

SCALE: 4:1

SHEET: 1 OF 1

REV: S1

Tyco Electronics Corporation  
 Harrisburg, Pa 17105-3608

NAME: TERMINAL, RING TONGUE, PVF2, P.I.D.G. WIRE SIZE: 12-10 AWG

SIZE: A3 CAGE CODE: 00779 DRAWING NO: C-53424 RESTRICTED TO: -